

Introduction

What is an Inverter?

Power inverter is an electronic device that converts low voltage DC (Direct Current) electricity from a battery or other power source to 100V-120V or 220V-240V AC (Alternating Current) household power. DC is the power that is produced by battery or other power source while AC is the standard power needed to run electrical equipment. A power inverter does the opposite of a rectifier and is used in places and situations where AC power is not available.

Modified Sine Wave: If your equipment can accept some voltage fluctuation, consider a modified sine wave inverter. These inverters provide mobile power at a more affordable price and come in a full range of size- from handheld to high performance. Do not use to power sensitive devices such as medical equipment or computers. Some audio equipment may perform poorly if run on Modified Sine Wave power

To ensure maximum reliability and efficiency, this inverter must be installed and used properly. Prior to installation, please read the user's manual. Improper usage may possibly lead to inverter damage, accidents, or injuries. Please read this manual, especially the "Precautions and Safety Notice" section to ensure your safety. After reading the instruction manual, please keep it with the warranty card for future reference.

Precautions

Please connect the red cable to the positive sign (+) and black to the negative (-). Make sure the cables are connected properly to prevent damaging the inverter.

DAMAGE CAUSED BY REVERSE POLARITY WILL NOT BE COVERED BY WARRANTY.

Please use the battery with the required input voltage. 12v inverter is compatible with 12v battery, while 24v inverter is for 24v battery.

Safety Notice

To help you avoid injuring yourself or other people, we have listed the following safety precautions.

- The inverter may produce sparks when connected to the battery. As such, when connecting the unit to a battery, make sure you do it in an area with no flammable gas. Battery Charging or discharging may produce flammable gases. Be sure to do it in a well-ventilated area. Proper Environment for the Inverter
- Output should not be parallel with the mains. It might damage the inverter and potentially cause electric shock.
- Keep the unit away from children. High output voltage might cause electric shock.
- Do not disassemble or modify the inverter. Unauthorized modification and disassembly of the unit may cause the inverter to malfunction or cause fire and electric shock.
- Do not expose the unit to liquids. Keep the unit dry at all times. Otherwise, it may lead to short circuit, fire, and electric shock.
- Do not insert any object into the vent or other openings. This may damage the inverter's internal components or cause electric shock and other injuries.
- Make sure the appliances / equipment you are using is properly plugged into the inverter. Failure to do so could lead to electric shock and overheating. It may even cause a fire accident. Do not use a damaged plug or loose electrical outlet.

- Do not touch the unit with wet hands, especially the power plug. This may cause electric shock.
- Keep volatile and combustible materials away from the unit.
- Do not damage the output sockets or wires.
- Do not cut, modify, distort, or reverse the wiring of the unit. Also, do not place the wires and cable near fire.
- Do not connect the inverter to appliances/equipment with broken wires or cables. It might cause electric shock, short circuit, or fire.
- Make sure to use the invert with the correct input voltage and ground wire power system.
- When in use, do not overload the unit. The overload protection circuit could invalidate or increase the overload protection power.
- Do not install the inverter while working in a hot and humid environment. Inverter leakage may cause electric shock or fire.
- This inverter has not been tested for use with medical equipment.

ATTENTION

1. Please use the appropriate cable when connecting the unit to an appliance/equipment. If the 230v output cable is too long or its cross-sectional area is too small, it could lead to power loss or poor load performance.
2. Also, please use the right set of cables when connecting the inverter to a battery or power source. Also, consider waterproofing and insulating them to meet environmental requirements.
3. The inverter can be used with the following products: Light bulb, fluorescent light, rice cooker, electric iron, desktop computer, laptop, fax machine, printer, LCD TV, fans, DVD player, cell phone charger, electric drill, electric iron, washing machine, hair dryer, amplifier, subwoofer etc.

Proper Environment for the Inverter

To get the best results, please place the inverter on a flat surface, such as the ground, the floor of the car, or other solid surface. The location where you are planning to install and place the inverter should meet the following criteria:

1. Dry. Place the inverter in a dry place. Do not let it get into contact with water, liquids or moisture.
2. Cool. Keep the temperature between 0 to 40 degrees Celsius. Do not place the inverter next to heat vents and other test devices. Also, avoid placing the inverter under direct sunlight.
3. Well-ventilated. Please make sure that the inverter is placed in a well-ventilated area, especially when in use. Do not place anything on or around the inverter, particularly near the exhaust fan.
4. Safe. Do not use the inverter in an area where combustible materials and flammable gases are present.
5. Fully charged battery. Please make sure that the battery you will use with the inverter is fully charged. Use good lead-acid batteries for best results.

Installation and Proper Usage

The inverter can be used with one or more batteries. Using 150AH or a larger battery is highly recommended.

Before connecting the inverter and battery, make sure that there is no flammable gas present. Use the cables that come with the unit to connect the inverter and battery.

Make sure to connect the red cable to the red post of the inverter and the positive terminal of the battery. Then, please connect the black cable to the black post of the inverter and the negative terminal of the battery. Please ensure that all connections are solid and reliable. Improper cable connections may result in overheating, as well as post head and lug damage. It can also reduce battery time.

When the inverter is switched on and your battery is fully charged, the power LED glows green. If the power LED glows red, there might be a problem. It can be the battery voltage is too high or too low, or the inverter output is overloaded. Find a way to solve the problem before using the unit.

12v inverter power source can be a 12v battery or a few 12v parallel batteries to increase power supply time.

Note: Before plugging in any appliance/equipment, make sure both the inverter and the appliance are turned off. When you turned the inverter on and the LED glows green, then you can switch on connected devices and appliances one by one. If the LED light is red, it means the inverter is overloaded. Restart the inverter or disconnect certain appliances to reduce the load.

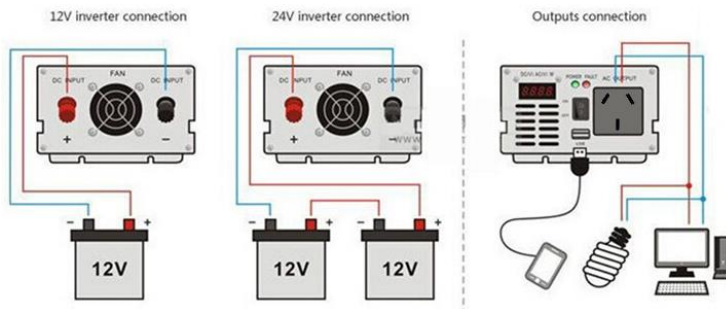

Note: The diagram is just for basic reference. Please contact a technician or a professional installer to ensure proper installation.

When installing the inverter, please refer to the diagram above.

1. First, make sure the inverter and its power source are turned off.
2. Connect the black DC cable to the negative terminal of the battery and to the black head post of the inverter.
3. Connect the red DC cable to the positive terminal of the battery and the red head post of the inverter.
4. Insert the power plug of the equipment you'd like to use into the inverter's output socket.
5. Switch on the inverter to start using the unit.

When disconnecting the inverter, please follow these steps:

1. Switch off the inverter and its power source.
2. Disconnect the equipment.
3. Disconnect the red DC cable.
4. Disconnect the black DC cable.

Operating Tips

Rated current and the actual used equipment

If the nominal current or power of electromotive tools, household appliances, and audio-visual equipment has a higher or lower range than normal, the inverter's overload protection will be triggered upon start-up. The inverter is also most likely to drive resistive loads and switch power supply load. Resistive load is usually linear and can work with full load. Examples of appliances with resistive load are electric stove, rice cooker, and LCD TV.

Some audio-visual equipment and electromotive tools need more power than the resistive load to work normally. Examples of these tools are an asynchronous motor, CRT TV, compressors, and pumps. They require two to six times the amount of the operating power to start. Test the equipment first before using it with the inverter.

Troubleshooting Tips

Problem: The inverter shut down and indicator light is off.

Possible cause 1: The battery is weak

Solution: Examine the battery and replace if necessary.

Possible cause 2: Batteries connected in reverse polarity.

Solution: Check the battery's connection, if any damage done to the inverter, it should be replaced

Possible cause 3: Poor contact at terminals

Solution: Unhook and re-hook the 12V connections and try again.

Problem: The inverter shut down and RED indicator is on

Possible cause 1: The rated power of AC product is higher than the nominal power of the inverter causes the overload shutdown.

Solution: Try to use AC electric products whose power level is less than the converters nominal power.

Possible cause 2: The power of AC electric product is less than the nominal power of the inverter, the rated power is quite high lead to overload shutdown.

Solution: The peak power of the AC electric product could be higher than that of the inverter, try to use electric products with the same peak power as the inverter.

Possible cause 3: The battery runs out

Solution: Charge or replace the battery

Possible cause 4: The ventilation is not well causing to overheat and shutdown.

Solution: Turn off the connected load device and let the inverter cool for about 15 minutes, remove all the item around the fan and inverter, then keep it in a cool place and restart it for powering a smaller load as required.

Possible cause 5: The input voltage is too high

Solution: Check the status of charging system and the 12V battery output

Problem: Output voltage of the inverter is too low

Possible cause 1: A general voltage meter used for measuring AC power gives small measurement range

Solution: True RMS Voltmeter is adopted for output measurement of the square wave inverter in order to obtain accurate data.

Problem: The inverter sends out alarm glare.

Possible cause 1: Low -voltage and overheat protection

Solution: Shorted the wire cable and use a thicker wire cable to charge the battery, the inverter can power small loads and would better to be placed in a well-ventilated area.

Problem: Inverter can only drive small power load

Possible cause: Electric power is being attenuated when electricity flows through the wire.

Solution: Shorten the wire cable and choose a thicker wire cable instead

Problem: The battery life is short

Possible cause 1: AC products power consumption is higher than rated load of inverter

Solution: Use larger capacity battery or replace battery

Possible cause 2: Battery is damaged or being charged insufficiently.

Solution: The battery never being charged sufficiently from battery chargers, therefore replace and use better intelligent battery charger

Possible cause 3: The electric current attenuates when flows through wire cable

Solution: Shorten the wire cable and try to use a thicker one instead.

Warranty

All products come with 1-year warranty. If the product is faulty, you may send the item back to Elinz, which will then send the product to the manufacturer on your behalf for repair. This warranty does not cover deliberate physical damage, severe moisture or electrocution due to static short circuiting, inserting the product into damaged equipment, or other activity the Customer engages in resulting in product damage.

Do you have more questions about the product or do you need further assistance? Visit www.elinz.com.au, Email: sales@elinz.com.au. You can also reach us at **1300 881 773**.